



STAY ALIVE FEEL ALIVE

HELLY HANSEN CUSTOMER STORY

Improving efficiency with automatic bagging



HH[®]
HELLY HANSEN



 Pregis





SAILING

TRUSTED BY PROFESSIONALS



ALIVE
SINCE 1877



OUTDOOR



ALIVE
SINCE 1877

TRUSTED BY PROFESSIONALS

From the home in Norway, **Helly Hansen** has been making professional grade gear to help people stay and feel alive for more than 140 years. Helly Hansen gear is worn and trusted by professionals on oceans, mountains and worksites.

Via Europe, the Helly Hansen gear and apparel is distributed all over the world (except for North America and Canada which are supplied from the distribution centre in Seattle).

In Born - the Netherlands, the 30.000 m² Helly Hansen distribution centre houses over 5 million of articles.

THE CHALLENGE

Since 2017 the volume growth of Helly Hansen Ecom business from Born has been Year Over Year over 43% at average. To keep up with demand Helly Hansen Born distribution centre was looking for a solution that would

- Reduce packing time
- Optimise labour
- Increase sustainability

THE SOLUTION

Helly Hansen was looking to improve the efficiency of the Ecom packaging process.



After a comparison between a horizontal bagging solution and the **Sharp Max Pro 24 vertical bagger**, Helly Hansen decided to invest in the Sharp solution because it met their requirements best:

- > High speed bagging
- > Reliable machine
- > Simple in use
- > Flexibility in bag dimensions
- > Best price/ quality investment
- > Improved sustainability

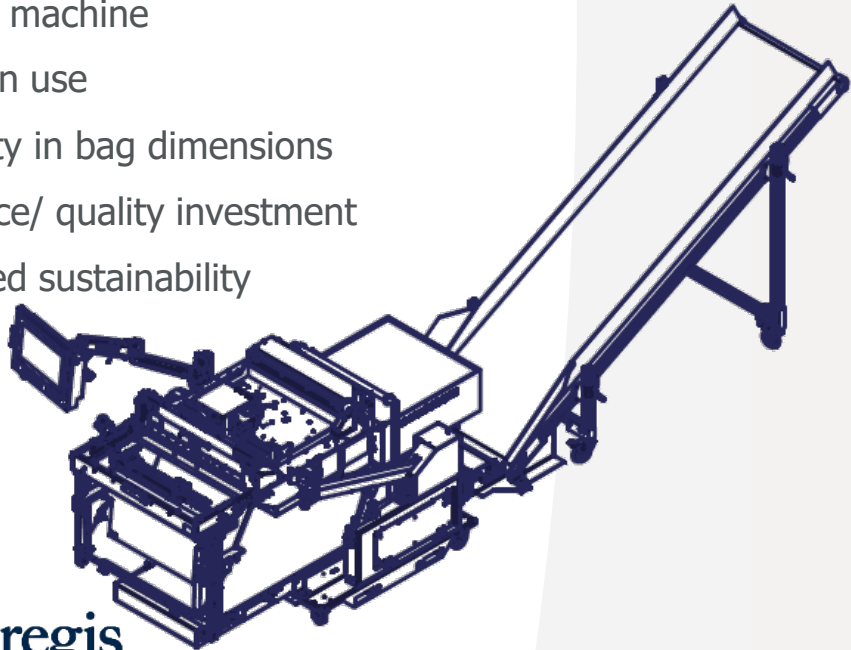



THE RESULT

High speed bagging



- > The bagging process with the Sharp Max Pro 24 means more output with fewer people. The original process of packing into boxes – taping and adding labels has been replaced by a process of – scanning the article – putting it into a pre-opened bag and pressing the button. The label is automatically printed on the bag.
- > The same volume can now be handled by 1 operator whereas previously 3 operators were needed.

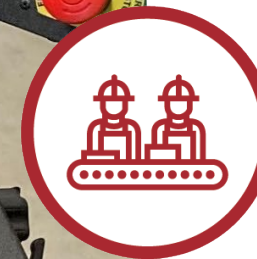

Reliable machine, simple in use

- > Operators do not need special training to work with the machine. It is easy to use and bag rolls can easily be exchanged. Malfunctions are minor and can be solved by the operators themselves.



THE RESULT

Best price/ quality investment

- > The investment in the Sharp Max Pro 24 was lower than investing in a horizontal bagging machine while at the same time the Sharp machine is more flexible and can handle different bag sizes.
- > Helly Hansen achieved additional savings on
 - > Labour: 1 packer can handle the same volume as 3 packers in the old situation
 - > Transportation – less volume – less transportation costs
 - > Material – polybags are less expensive than the corrugated folding boxes they replace

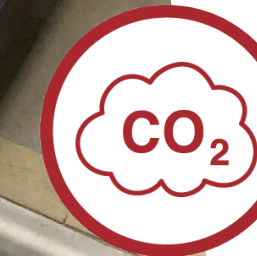

Sustainable

- > The polybags are 100% recyclable and contain 30% recycled content with the goal of maximising the recycled content to 80%.
- > The shipping information is thermally imprinted directly onto the bag – making it possible to dispose of the bag with plastic waste and recycle it to serve a new purpose.
- > Compared to the boxes, the small weight and volume of the bags lead to a reduction in CO₂ footprint.

DENNIS RUTTEN
Warehouse Manager
at the Helly Hansen
distribution centre in Born,
the Netherlands



"The speed of the machine is impressive. As we grow in Ecom volumes and with Black Friday coming up, we can really take advantage of this machine to ensure fast delivery time for all our customers."

The cooperation between Helly Hansen and Pregis in the integration process was smooth and very pleasant. The communication and service are of a high standard.

I would recommend the Sharp Max Pro 24 to other companies because the machine is very user-friendly, reliable and fast."

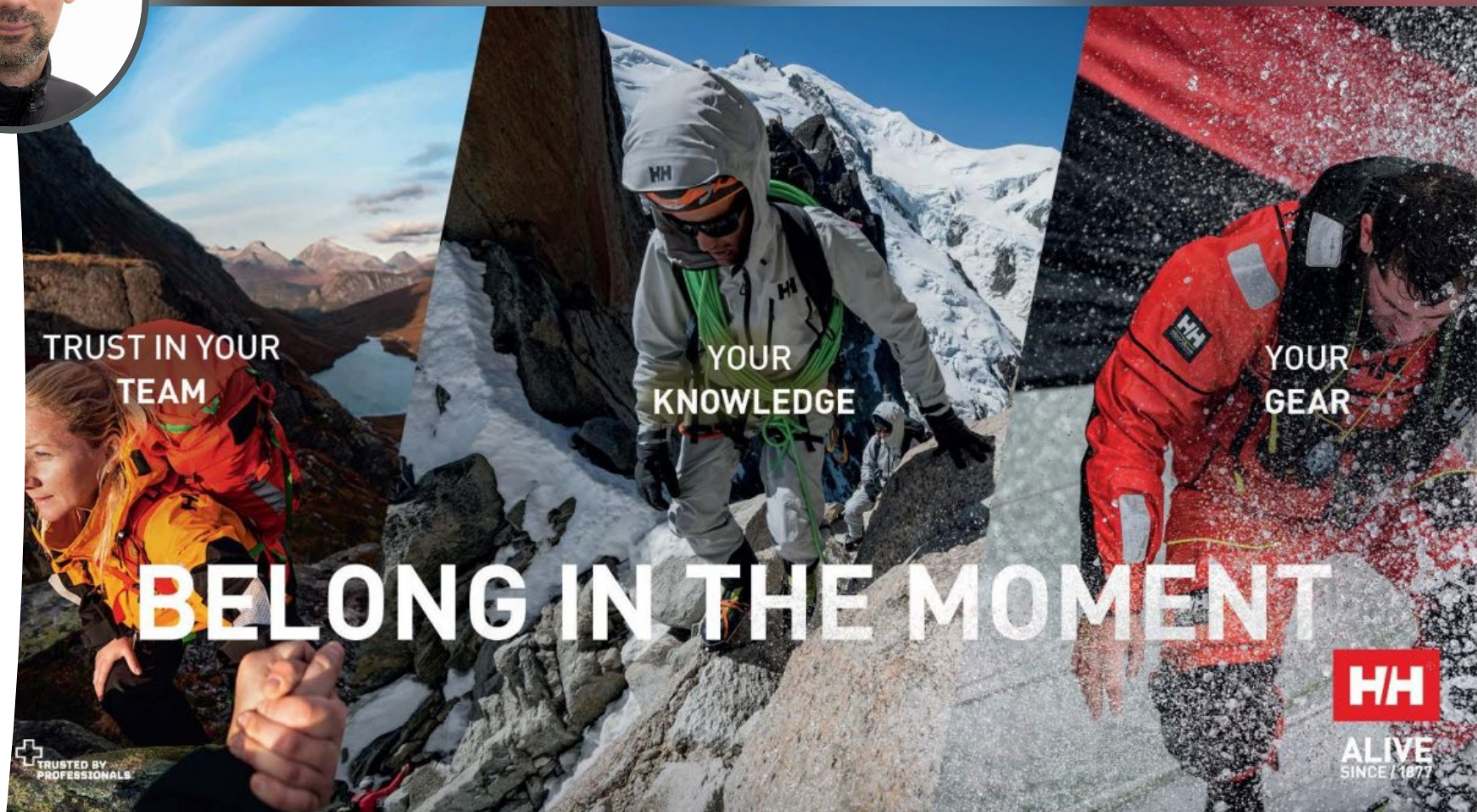

TRUST IN YOUR
TEAM

YOUR
KNOWLEDGE

YOUR
GEAR

BELONG IN THE MOMENT

TRUSTED BY
PROFESSIONALS

HH

ALIVE
SINCE 1877



Pregis

PROTECT, PRESERVE & INSPYRE



00800 8888 8840

Customer.care@pregis.com

www.PregisEU.com